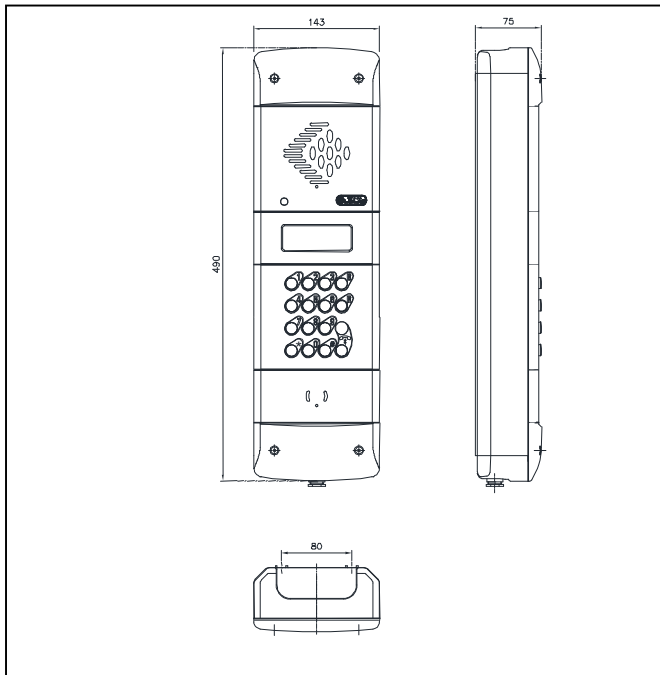

TELEPHONES LE LAS

Tel:.....(33) 1 48766262
 Fax:(33) 1 48768304
 E-mail:lelas@lelas.fr
 Web-site:**www.lelas.fr**

Telephone set used for indoor and outdoor industrial environment

Dimensions Drawing

TLX 306 H5 CL9M
Electrical Characteristics :

| | |
|---------------------------|---------------|
| Line voltage : | 20 à 60 Vcc |
| Walking consumption Max.: | 40mA ±3 |
| Consumation repos : | ≤15µA |
| Ringing voltage : | 30 – 80 Vac |
| Loudspeaker : | 5 Watts |
| Sound Call waiting : | > 85dB / 1 m. |
| Talk mode : | hands free |
| Hang up : | Automatic |

Other characteristics: CCITT Q23

Options:

- Box for wall-mounted
- Relay Board

Material / Color :.....Aluminium / Grey RAL7047
 Microphone :.....electret waterproof type
 Weatherproof Speaker :.....5 watts
 Fixation :.....flush mounting or wall mounting
 Connection:..... lockable and removable connector
 Cable type :..... single son or stranded max section 1.5mm²
 Cable entry: type for cable up to Ø15mm
 Dimension :490 X 143 X 45.5 mm
 Weight :1.8 kg
 Ingress Protection (IP) :.....IP66
 Operating temperature:.....-25°C / +65°C

Procedure for installation and maintenance :

- Opening and closing on gasket by 4 stainless steel screws.
- Connection of the telephone line by removable connector admit son mono or standard with a maximum section of 1.5mm².

This equipment comes with a warranty of 2 years parts and hands to work in factory output.